

### MANUFACTURER'S WARRANTY

*Manufacturer's guarantee only applies on items that are defective in normal use-conditions. It applies during one year after the purchase date. If any items are defective, it has to be returned to ERDE SAS with purchase proof after having received an explicit agreement of ERDE. Any non-authorized returns would not be acceptable. Postage costs of return have to be paid by the customer. These costs would be paid back if the manufacturer's guarantee is involved.*

## ASSEMBLY AND USE INSTRUCTIONS

### DAXARA TRAILERS

#### ➤ Model 239X4F



### Equipments available as options

Flat soft cover



High trailer cover with frame 30 cm



High trailer cover With frame 60 cm



Universal load bars



Side height extensions



Hard top cover



Load bars for hard top cover



Stabilising propstands (pair)



Mesh sides



Cover for mesh sides



Coupling lock



Spare wheel With or without support



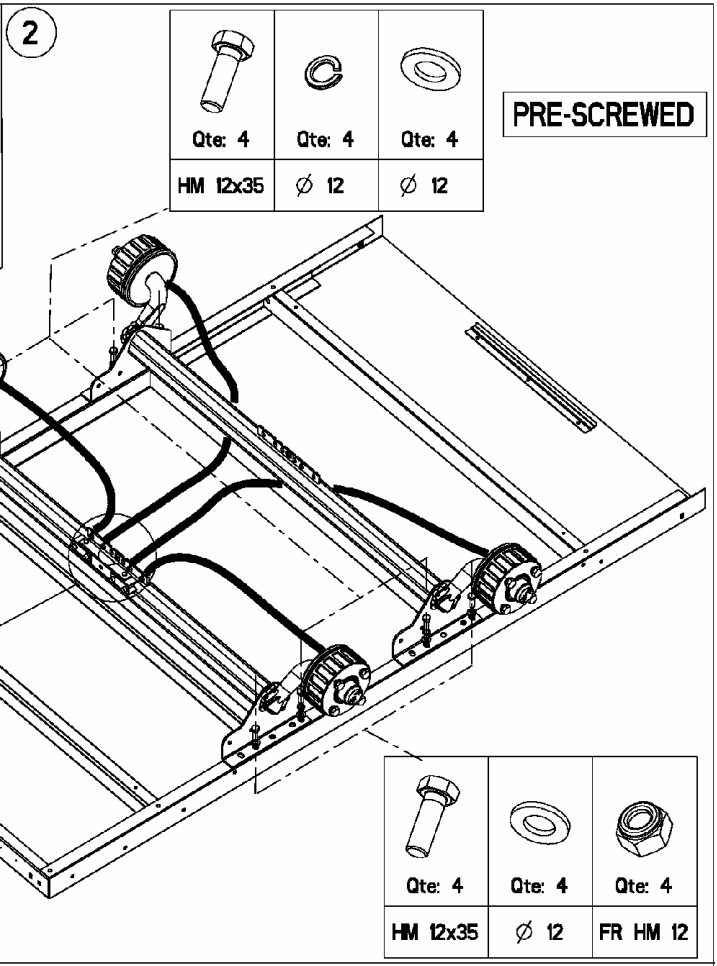
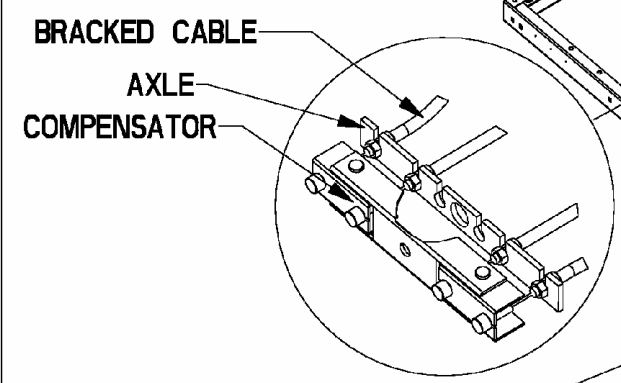
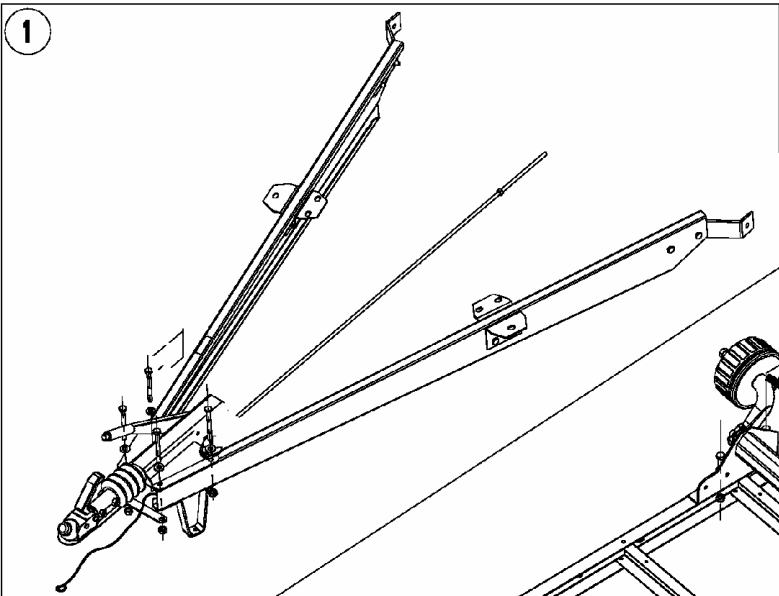

1 FIX BRACKED CABLE ON AXLE  
2 FIX COMPENSATOR ON BRACKED CABLE

**3 TIGHTEN ALL FASTENINGS**

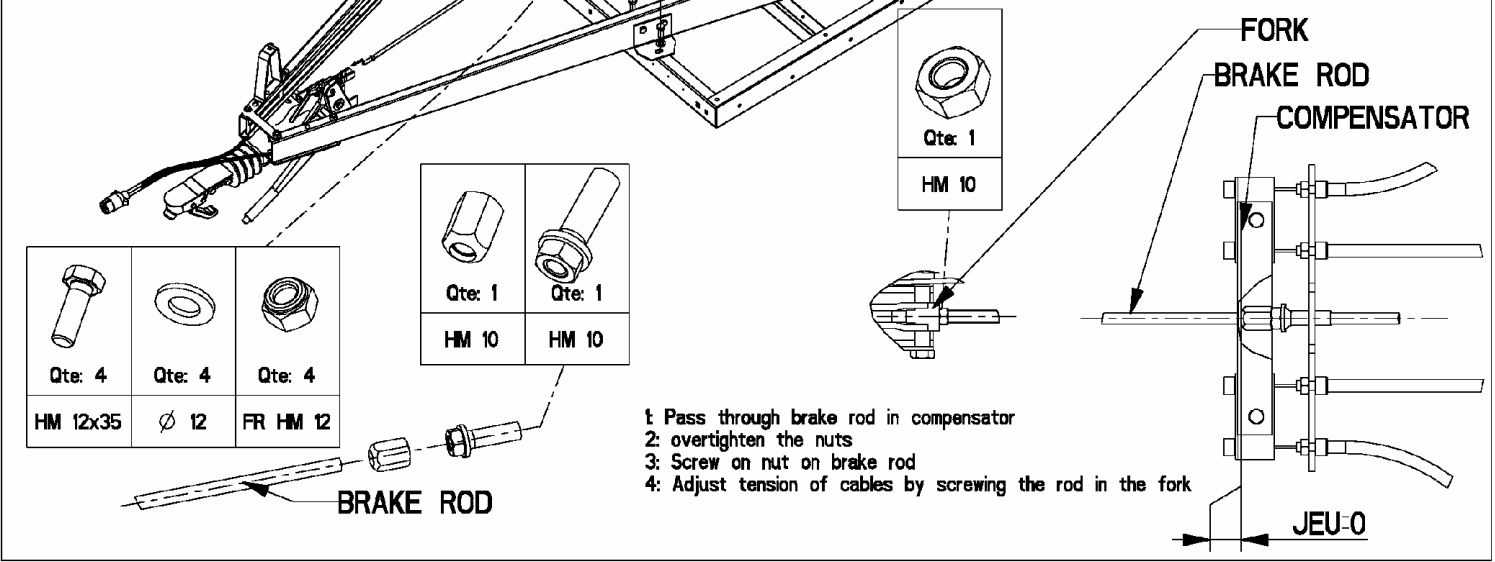
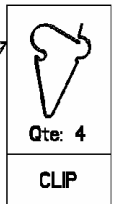
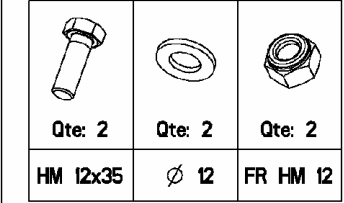

- 1: Pass through brake rod in compensator
- 2: overtighten the nuts
- 3: Screw on nut on brake rod
- 4: Adjust tension of cables by screwing the rod in the fork

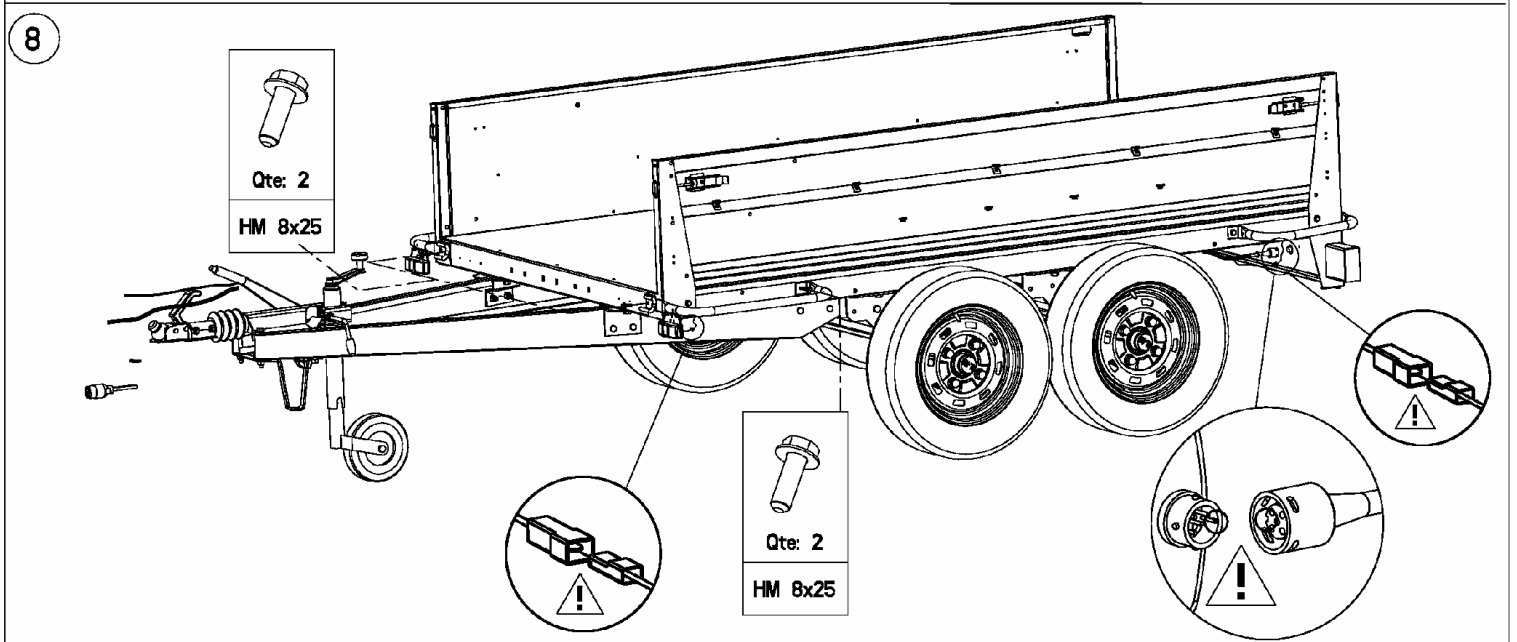
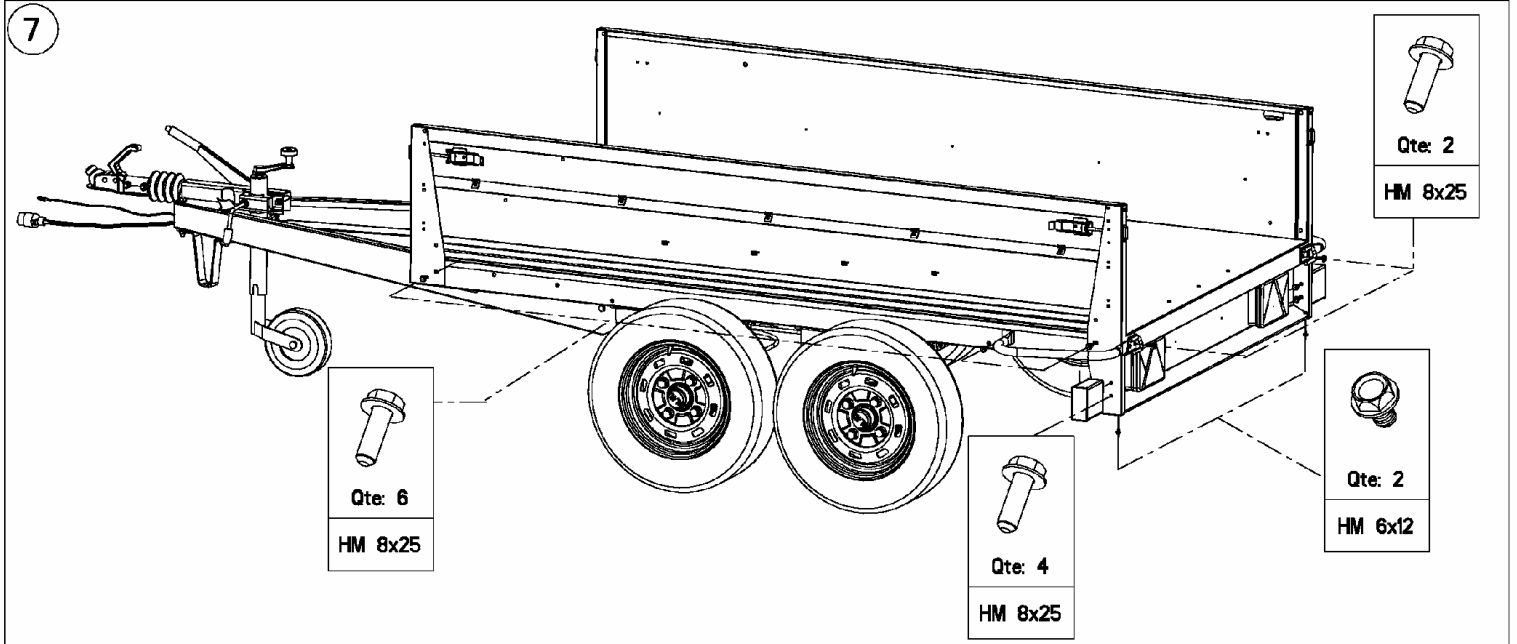
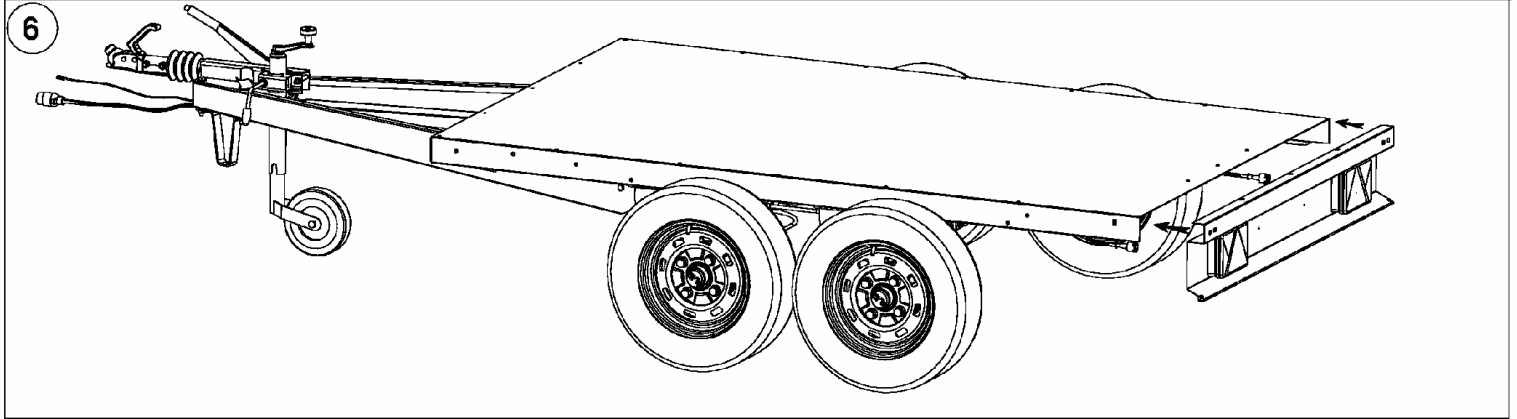
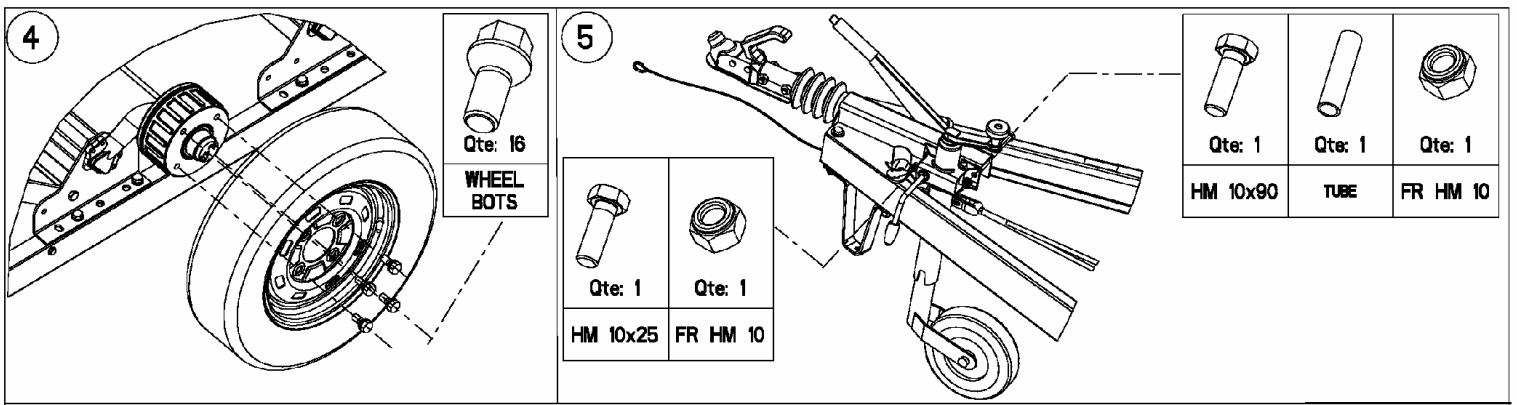

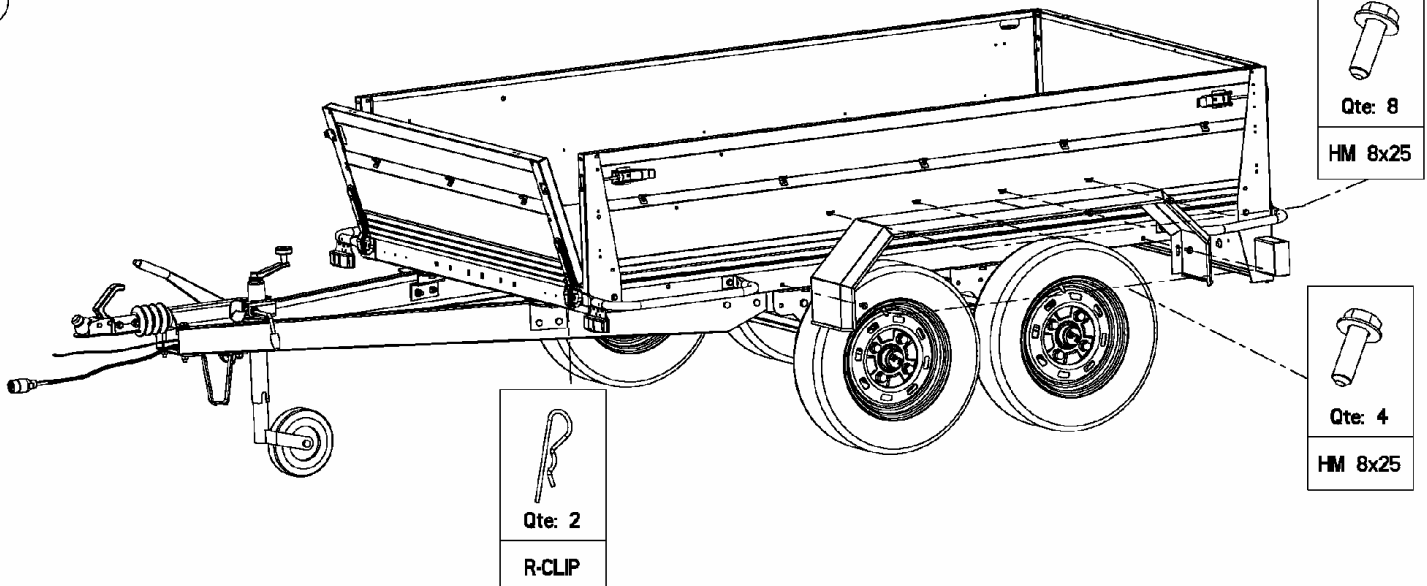

## TIGHTEN FIRMLY ALL WHEEL NUTS AND ALL OTHER NUTS AND BOLTS

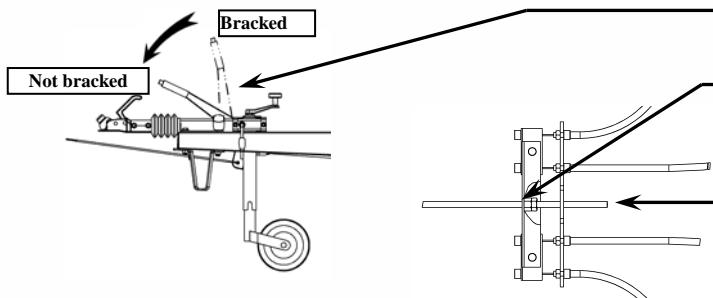

- Activate the brake 3 or 4 times
- When it is not braked position, tight circular nut until the limit of wheel locking
- Unscrew circular nut 2 or 3 turns
- Check free rotation of the wheels, then tight the lock nut

## TRAILERS - USE AND MAINTENANCE

### 1 - COUPLING

On the drawbar: all trailers are equipped with a 50mm ball coupling with safety catch, which prevents the trailer becoming detached.

#### COUPLING AND UNCOUPLING OF TRAILER:

Proceed as follows: lift the end of the handle attaching the coupling to the tow ball, operating at the same time the locking trigger on the handle.

Option: It is possible to install an anti theft device that locks the coupling and provides added security.

On the car: towing brackets of a recognised standard should be fitted.

### 2 - MAINTENANCE

#### AFTER THE FIRST 60 MILES? CHECK THE TIGHTNESS OF ALL NUTS/BOLTS OF THE FOLLOWING MAIN PARTS

- \* WHEELS \* AXLE \* DRAWBAR \* COUPLING HEAD
- \* MUDGUARDS \* LIGHTING

### 3 - HUBS

The wheel hubs including bearing are pregreased for life. No greasing needs to be done.

### 4 - ELECTRICAL CONNECTIONS

The electrical fittings are based on the European standards system equivalent BS 149A:

- Contact Block N°1 – Left indicator ( yellow or orange wire)
- Contact Block N°2 – Fog lamp ( blue wire)
- Contact Block N°3 – Earth ( white wire)
- Contact Block N°4 – Right indicator ( green or violet wire)
- Contact Block N°5 – Right tail + N° plate lights ( brown wire)
- Contact Block N°6 – Stop lights ( red wire)
- Contact Block N°7 – Left tail + N° plate lights (black wire)

### 5 - TYRE PRESSURE

Inflation pressure should be checked regularly to avoid any risk of abnormal wear and punctures.

- 350x8 wheel: 2,5 bar/36 LBS per SQ inch
- 400/480x8 wheel: 2,5 bar/36 LBS per SQ inch
- 400x10 wheel: 3,5 bar/50 LBS per SQ inch
- 500x10 wheel: 3,5 bar/50 LBS per SQ inch
- 135x13 wheel: 2,5 bar/36 LBS per SQ inch
- 145x13 wheel: 2,5 bar/36 LBS per SQ inch
- 185x13 wheel: 2,5 bar/36 LBS per SQ inch

If heavily loaded, or for long trips, it is necessary to increase tyre pressure by 0,50 bars.

### 6 - LOADING

All loads should be evenly spread. For your own safety it is important that the trailer is not over loaded. The suspension units and tyres are designed to carry the following maximum weights.

**It is an offence to load the trailer to more than its marked gross weight.**

### 7 - SOME ADVICE

Before use, check:

- \* Tyre pressure
- \* Lighting
- \* Coupling
- \* If load is well tightened
- \* Registration plate: the number plate of the trailer must be identical to the towing vehicle.
- \* Never carry anybody in your trailer

#### How to maintain your trailer?

You should wash your trailer regularly, particularly after having carried dirty material and after having driven on salty roads that are treated against snow.